

EN 12900 LBP

220V, 50Hz, fan cooling F₂

Evap. temp. in °C	-45	-40	-35	-30	-25	-23.3	-20	-15	-10	-6.7	-5	0	5	7.2	10	15	20
Capacity in W			153	212	281	308	364	463	581	671.6	722	888	1083	1178	1309		
Power cons. in W			149	171	195	203	220	246	275	294	305	337	372	387	409		
Current cons. in A			1.43	1.46	1.51	1.53	1.57	1.64	1.72	1.78	1.81	1.91	2.01	2.06	2.12		
COP in W/W			1.03	1.24	1.45	1.52	1.66	1.88	2.12	2.28	2.37	2.64	2.91	3.04	3.20		

EN 12900 MBP

220V, 50Hz, fan cooling F₂

Evap. temp. in °C	-45	-40	-35	-30	-25	-23.3	-20	-15	-10	-6.7	-5	0	5	7.2	10	15	20
Capacity in W			131	189	257	282	337	432	545	631	679	838	1024	1115	1240		
Power cons. in W			149	173	198	207	225	253	282	303	314	347	383	399	421		
Current cons. in A			1.43	1.47	1.52	1.54	1.58	1.66	1.75	1.81	1.85	1.96	2.08	2.13	2.20		
COP in W/W			0.88	1.09	1.29	1.36	1.50	1.71	1.93	2.08	2.16	2.41	2.68	2.79	2.95		

ASHRAE LBP

220V, 50Hz, fan cooling F₂

Evap. temp. in °C	-45	-40	-35	-30	-25	-23.3	-20	-15	-10	-6.7	-5	0	5	7.2	10	15	20
Capacity in W			116	184	261	290	351	457	584	681	735	914	1125	1229	1372		
Power cons. in W			127	157	189	200	221	254	289	313	325	363	402	420	443		
Current cons. in A			1.40	1.45	1.51	1.54	1.59	1.69	1.80	1.89	1.93	2.07	2.23	2.30	2.39		
COP in W/W			0.92	1.17	1.38	1.45	1.59	1.80	2.02	2.18	2.26	2.52	2.80	2.93	3.10		

ASHRAE MBP

220V, 50Hz, fan cooling F₂

Evap. temp. in °C	-45	-40	-35	-30	-25	-23.3	-20	-15	-10	-6.7	-5	0	5	7.2	10	15	20
Capacity in W			104	164	233	258	313	407	520	606	654	813	999	1091	1217		
Power cons. in W			126	156	187	198	219	252	286	309	322	359	397	415	437		
Current cons. in A			1.40	1.45	1.51	1.54	1.59	1.69	1.80	1.86	1.93	2.07	2.23	2.30	2.39		
COP in W/W			0.83	1.05	1.24	1.31	1.43	1.62	1.82	1.96	2.03	2.27	2.52	2.63	2.78		

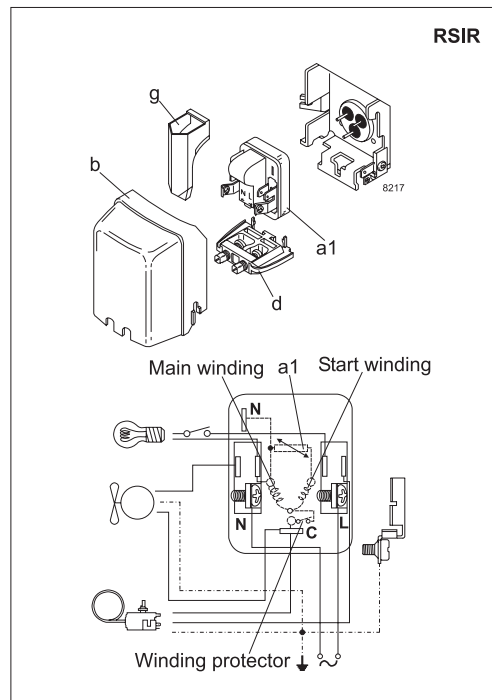
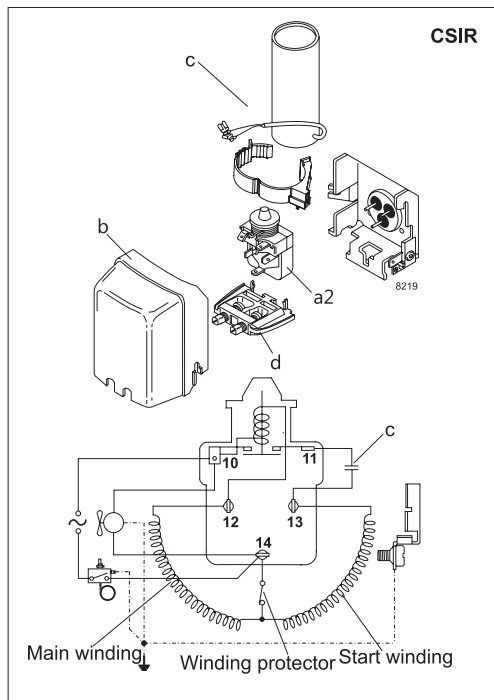

Accessories for	NLE10MF.2	Figure	Code number
ePTC starting device	6.3 mm spade connectors	a1	-
	4.8 mm spade connectors		103N0050
Starting relay	6.3 mm spade connectors	a2	117U6002
Start. capacitor 80 µF	6.3 mm spade connectors	c	117U5015
Cover		b	103N2010
Cord relief		d	103N1010
Protection screen for PTC		g	-

Test conditions	EN 12900		ASHRAE	
	LBP	MBP	LBP	MBP
Condensing temperature	40°C	45°C	54.4°C	54.4°C
Ambient temperature	32°C	32°C	32.2°C	35°C
Suction gas temperature	20°C	20°C	32.2°C	35°C
Liquid temperature	no subcooling		32.2°C	46.1°C

Mounting accessories	Code number	
Bolt joint for one comp.	Ø: 16 mm	118-1917
Bolt joint in quantities	Ø: 16 mm	118-1918
Snap-on in quantities	Ø: 16 mm	118-1919

EN 12900 LBP

 220V, 50Hz, RC 4 µF, ePTC consumption incl., fan cooling F₂

Evap. temp. in °C	-45	-40	-35	-30	-25	-23.3	-20	-15	-10	-6.7	-5	0	5	7.2	10	15	20
Capacity in W			153	212	281	308	364	463	581	671	721	887	1082	1177	1308		
Power cons. in W			141	162	185	193	209	234	261	279	289	320	353	368	388		
Current cons. in A			1.36	1.39	1.43	1.45	1.49	1.56	1.63	1.69	1.72	1.81	1.91	1.95	2.01		
COP in W/W			1.09	1.31	1.52	1.60	1.74	1.98	2.23	2.40	2.49	2.77	3.07	3.20	3.37		

EN 12900 MBP

 220V, 50Hz, RC 4 µF, ePTC consumption incl., fan cooling F₂

Evap. temp. in °C	-45	-40	-35	-30	-25	-23.3	-20	-15	-10	-6.7	-5	0	5	7.2	10	15	20
Capacity in W			131	189	257	282	336	431	544	630	678	837	1023	1114	1239		
Power cons. in W			142	164	188	197	213	240	268	288	298	329	363	379	399		
Current cons. in A			1.36	1.39	1.44	1.46	1.50	1.57	1.66	1.72	1.75	1.86	1.97	2.02	2.09		
COP in W/W			0.93	1.15	1.36	1.43	1.57	1.80	2.03	2.19	2.28	2.54	2.82	2.94	3.10		

ASHRAE LBP

 220V, 50Hz, RC 4 µF, ePTC consumption incl., fan cooling F₂

Evap. temp. in °C	-45	-40	-35	-30	-25	-23.3	-20	-15	-10	-6.7	-5	0	5	7.2	10	15	20
Capacity in W			116	184	260	289	350	456	583	680	734	913	1124	1228	1370		
Power cons. in W			120	149	179	189	210	242	274	297	309	344	381	398	420		
Current cons. in A			1.33	1.37	1.43	1.46	1.51	1.60	1.71	1.79	1.83	1.97	2.11	2.18	2.27		
COP in W/W			0.97	1.23	1.45	1.53	1.67	1.89	2.12	2.29	2.38	2.65	2.95	3.08	3.26		

ASHRAE MBP

 220V, 50Hz, RC 4 µF, ePTC consumption incl., fan cooling F₂

Evap. temp. in °C	-45	-40	-35	-30	-25	-23.3	-20	-15	-10	-6.7	-5	0	5	7.2	10	15	20
Capacity in W			104	164	232	258	312	407	519	605	653	812	998	1090	1216		
Power cons. in W			119	148	177	188	208	239	272	294	305	340	377	394	415		
Current cons. in A			1.33	1.37	1.43	1.46	1.51	1.60	1.71	1.79	1.83	1.97	2.11	2.18	2.27		
COP in W/W			0.87	1.11	1.31	1.38	1.50	1.70	1.91	2.06	2.14	2.38	2.65	2.77	2.93		

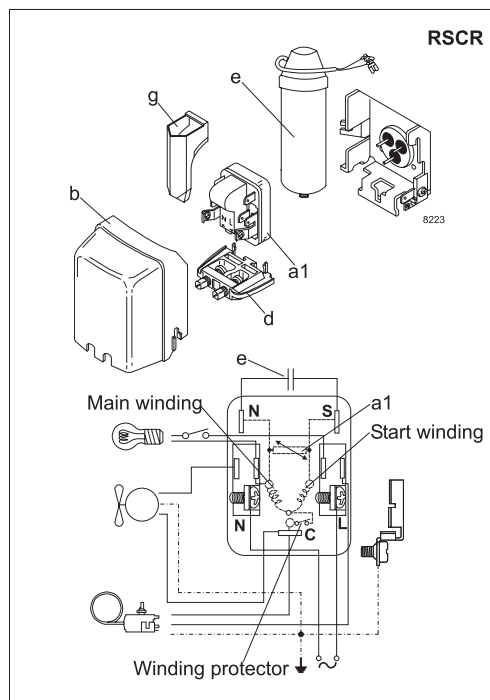

Accessories for	NLE10MF.2	Figure	Code number
ePTC starting device	6.3 mm spade connectors	a1	-
	4.8 mm spade connectors		103N0050
Run capacitor 4 µF (optional)	4.8 mm spade connectors	e	117-7119
Cover		b	103N2010
Cord relief		d	103N1010
Protection screen for PTC		g	-

Test conditions	EN 12900		ASHRAE	
	LBP	MBP	LBP	MBP
Condensing temperature	40°C	45°C	54.4°C	54.4°C
Ambient temperature	32°C	32°C	32.2°C	35°C
Suction gas temperature	20°C	20°C	32.2°C	35°C
Liquid temperature	no subcooling		32.2°C	46.1°C

Mounting accessories	Code number	
Bolt joint for one comp.	Ø: 16 mm	118-1917
Bolt joint in quantities	Ø: 16 mm	118-1918
Snap-on in quantities	Ø: 16 mm	118-1919

Secop can accept no responsibility for possible errors in catalogues, brochures and other printed material. Secop reserves the right to alter its products without notice. This also applies to products already on order provided that such alterations can be made without subsequential changes being necessary in specifications already agreed. All trademarks in this material are property of the respective companies. Secop and the Secop logotype are trademarks of Secop GmbH. All rights reserved. www.secop.com